

# Merlin PLUS



## 6 Remotes in every box

Rapidly expand your remote capability by using Merlin PLUS to create and manage up to 6 independent bidirectional mono connections with IP codecs or smartphones using Report-IT, and at the same time save money on codec hardware costs and reduce studio rack space requirements.

Merlin PLUS can also deliver high fidelity, bidirectional stereo IP audio and full-duplex communications from the studio to a remote codec.

### Flexible Applications

Merlin PLUS is the ideal 1RU codec for studio installations and offers a simple, compact and scalable solution for managing multiple simultaneous remotes. Use Merlin PLUS for:

- Up to 6 simultaneous bidirectional mono remote connections.
- 1 or 2 stereo remote connections (bidirectional), each with separate IFB communication channels.
- Recallable codec configurations via 'programs'.

### Reliability and Connectivity

Merlin PLUS is specifically designed to deliver remote broadcast connections over the full suite of wired and wireless IP networks. The codec features dual Gigabit Ethernet ports, dual redundant power supplies and IP network backup, as well as SmartStream PLUS redundant IP streaming to ensure you're always on the air.

### SmartStream PLUS Saves Money

Merlin PLUS uses intuitive and adaptive SmartStream IP technology

to adapt effortlessly to variable IP network conditions and deliver seamless bidirectional audio over wireless connections<sup>[1]</sup>, which can be susceptible to packet loss over time.



SmartStream PLUS software has revolutionised IP broadcasting by streaming simultaneous redundant data streams from both Ethernet ports to deliver seamless redundancy over inexpensive IP links. This maintains rock solid audio over unmanaged IP networks like the internet, allowing you to perform reliable high quality remotes at a fraction of the cost of synchronous leased lines.

Some other manufacturers charge thousands for IP management software like SmartStream as if it's an optional extra. Tieline believes high performance and rock-solid reliability is an essential part of each and every broadcast and delivers its renowned SmartStream and SmartStream PLUS software for free in Merlin PLUS.

### Compatibility

Merlin supports both IPv4 and IPv6 (Dual Stack) protocols, so broadcasters can be assured that they have made a smart investment for the future. You can also connect over IP with any SIP-enabled IP codec brand supporting the EBU N/ACIP tech 3326 standard.

It is also compliant with I3P EBU3347 requirements for interoperability of AoIP production intercoms.

### Algorithms

The codec includes the low delay and cascade-resilient E-apt-X algorithm, as well as other popular algorithms including the full AAC suite, variable bit-rate Opus, MPEG Layer II, MP3, Tieline Music and MusicPLUS, G.722 and G.711. Asymmetric<sup>[2]</sup> encoding and decoding lets you send high quality audio in one direction and save on data by sending low bandwidth program on the return path.



Merlin PLUS connecting 6 remotes simultaneously

### Codec Management

Each device can be individually controlled and fully configured using a Java-based web browser Graphical User Interface launched from each codec.

Merlin is also designed to be managed using Tieline's standalone Codec Management System<sup>[3]</sup> (CMS), which can be used to managed your entire network of IP codecs remotely.

**Tieline**<sup>®</sup>  
The Codec Company

[1]Requires 3rd party device [2]Future Release [3]Sold Separately

## Input/Output Specifications

Analog Audio Inputs	2 x Female XLR line inputs
Analog Audio Outputs	2 x Male XLR
AES3 In	1 x female XLR (Channel 1 in; shared with Ch1 analog input)
AES3 Out	1 x male XLR
Aux Input	1 x 6.35mm (1/4") Mic/Line level Jack on rear panel
Headphones Out/Aux Out	1 x 6.35mm (1/4") Jack on rear panel and 1 x 6.35mm (1/4") Jack on the front panel
Female DB25	4 Channel audio expansion connector
Sync Input	BNC Wordclock input
Control Port In/Out	Four relay inputs and four opto-isolated outputs for machine control via a DB15 connector.
Audio Input Impedance	High Impedance > 5K ohm
Output Impedance	<50 ohm Balanced
Clipping Level	+22dBu (input and outputs)
A/D & D/A Converters	24 bit
Frequency Response	20Hz to 22kHz
Total Harmonic Distortion	<0.0035% at +16dBu or -89 dBu unweighted
Signal To Noise Ratio	>98.5dB at +22dBu, unweighted

### Sample Frequencies

IP Sample Frequencies	8kHz, 16kHz, 24kHz, 32kHz, 44.1kHz, 48kHz
-----------------------	-------------------------------------------

### Algorithms

IP	Tieline Music, Tieline MusicPLUS, Opus, G.711, G.722, MPEG Layer 2, MPEG Layer-3
IP (uncompressed)	LC-AAC, HE-AAC, HE-AACv.2, AAC-LD, AAC-ELD, AAC-ELDV2, 16/24 bit Enhanced apt-X Linear PCM16/24 bit 32kHz, 44.1kHz, 48kHz

### Data and Control Interfaces

USB	USB 2.0 Host port on the front panel
LAN	2 x 10/100/1000 RJ45 connectors
Serial Protocols	RS232 up to 115kbps with or without CTS/RTS flow control can be used as a proprietary data channel Tieline; SIP (EBU N/ACIP 3326 compliant); IPv4/IPv6 compatible; I3P EBU3347 Compliant
ISDN	Optional via module slot**
POTS	Optional via module slot**

### Front Panel Interfaces

Display	256 x 64 monochrome LCD
Keypad	21 button keypad
Navigation	5 button keypad

### General

PC Configuration	User-configurable settings and matrix audio mixer** via browser-based Toolbox Graphical User Interface
Multilingual	Multilingual menus and configuration software
Remote Control	Compatible with Codec Management System software (optional purchase)
Size	1U x 19" Rackmount
Dimensions	19" x 1.75" x 13.5" [482mm (W) x 44mm (H) x 343mm (D) including rear connectors]
Weight	6lb 3.47oz/2.82Kg
Power Consumption	Dual 100-240V IEC power inlets; 1A 50-60Hz
Operating Temperature	0°C to 45°C (40°F to 113°F)
Humidity Operating Range	20% ≤ RH ≤ 70% (0 to 35°C), non-condensing.

\*\* Available in later releases

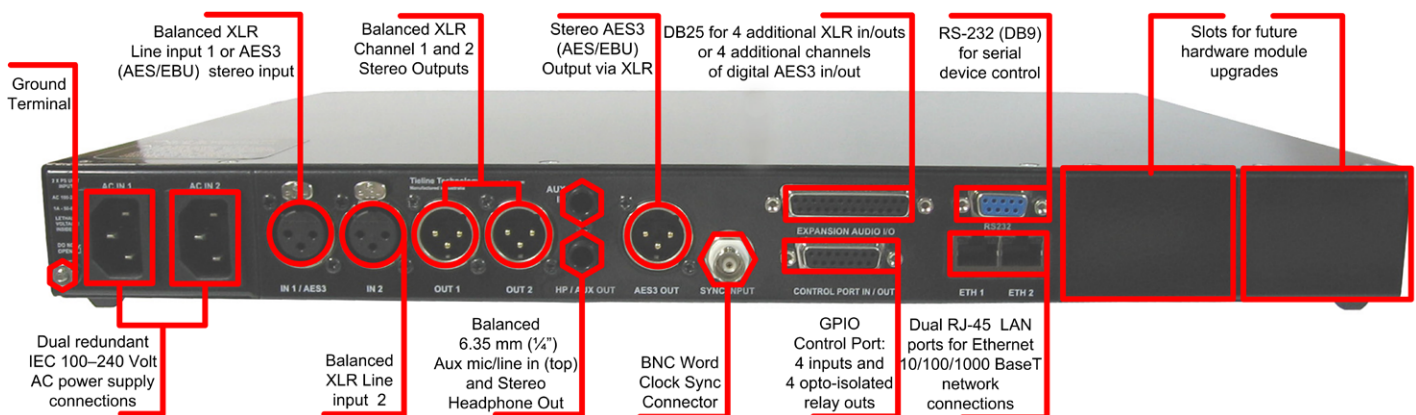

### FRANCE

SAVE DIFFUSION  
23 Rue de la Taladiere  
42000 ST ETIENNE - France  
tel. +33 4 77 79 46 78  
email : commercial@savediffusion.fr  
www.savediffusion.fr

### International

Tieline Pty Ltd  
1/25 Irvine Drive  
Malaga, WA. 6090 Australia  
Ph: +61(0)8 9249 6688  
Fax: +61(0)8 9249 6858  
E-mail: info@tieline.com

**Tieline**  
The Codec Company