

# TELOS PROSTREAM

## HARDWARE STREAMING AUDIO ENCODER



### MEET TELOS PROSTREAM: INTERNET STREAMING IN A BOX.

We're often asked, "How do I stream audio to listeners over the Internet?" Too often the answer included mini-jacks, poor-quality sound cards, a PC to maintain, and a collection of software that didn't always play nicely together.

ProSTREAM from Telos makes netcasting a lot easier. ProSTREAM combines Omnia audio processing that makes Internet-delivered audio sound its best, with the latest and most widely used audio codecs. We go one step further and add metadata embedding in popular formats.

The Telos ProSTREAM is a single box - an appliance - that simplifies getting your audio streaming on the 'Net. Put audio into the ProSTREAM, make a few setup selections, and stream your audio perfectly to most any stream server or streaming service for worldwide distribution.

### ABOUT TELOS

Steve Church founded Telos Systems in 1985. As both a talk show host and radio group Technical Director, Steve was only too familiar with the frustrations of "bad phones" and even less responsive equipment manufacturers, so he set about eliminating the technical problems that plagued radio call-in seg-

ments. In 1984, he invented the Telos 10, the first DSP-based telephone-to-broadcast interface system - allowing radio stations to significantly improve the technical quality of call-in segments. The overwhelming response to Steve's economical and technically elegant solution to a nagging problem provided the spark from which Telos was born.

A lot's happened since then. We pioneered the use of MPEG Layer 3 coding in the revolutionary Zephyr ISDN codec. We produced the first hardware MP3 streaming encoder for broadcast. We developed the world's first "whole-plant" broadcast phone system. And we invented the IP-networked radio console, and then integrated broadcast phones into that network via Ethernet.

Telos has grown steadily since our initial production run of 25 Telos 10 units in 1985! With tens of thousands of systems in the field, it now is hard to find a broadcast facility in the world without at least one piece of our gear. Our organization, now called The Telos Alliance, includes the Omnia Audio, Axia Audio and Linear Acoustic brands, and our R&D department - the largest research team in broadcasting - continues to develop innovative audio products for radio and television broadcasting, telephony, and the Internet.

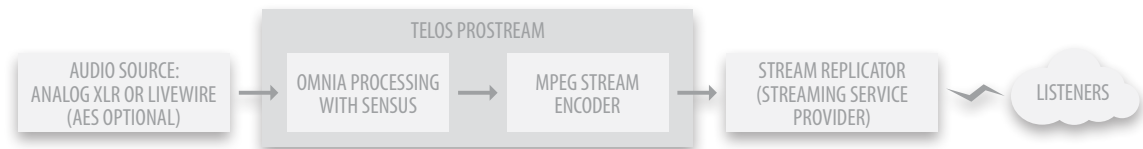

## THE ALL-IN-ONE STREAMING SOLUTION FOR AUDIO PROFESSIONALS.

Over the last two decades, Telos has become broadcasting's acknowledged codec expert. ProSTREAM puts all of our expertise into a single, integrated streaming appliance; a rack-mounted, multi-DSP unit dedicated to making your Web presence sound its absolute best.

Why a hardware solution? Up 'til now, producing streaming audio involved multiple PCs running multiple programs, sometimes with multiple operating systems and multiple licenses to maintain. One box to pre-process your audio; fed to a second box for actual encoding, and finally to a streaming platform to deliver to your ISP for distribution.

ProSTREAM simplifies streaming by placing all three processes in a single, hardened, rack-mount device. A single point of control for every part of your streaming operation – all accessible by remote control via LAN or WAN.



## QUICK AND EASY

The best thing about Telos ProSTREAM may just be that it's an all-in-one streaming solution. ProSTREAM is neatly self-contained in a 1RU box — just slide it into a rack and it's ready to go – no running your mission-critical audio over crash-prone PC hardware and operating systems. Adjust the audio input levels, define a metadata source, select a processing preset, codec, and bitrate. Then, select a target media server. The front panel even has a built-in headphone amp with 1/4" jack and volume control for monitoring input or output audio.

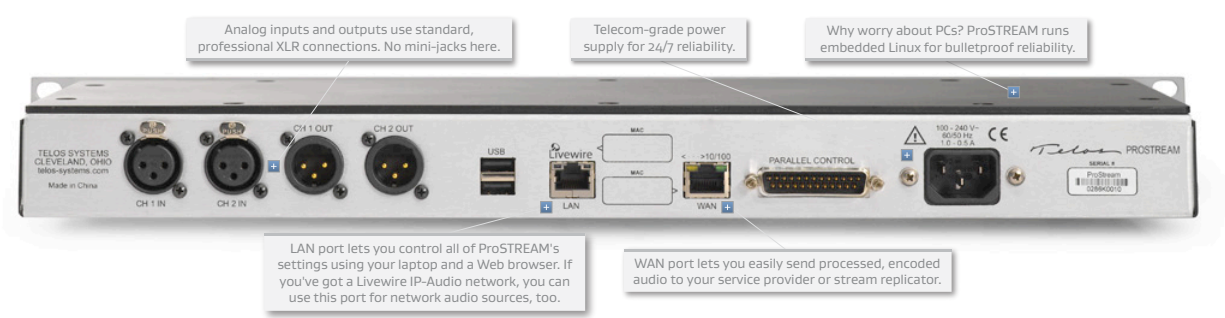

## AROUND THE BACK

On the input side, ProSTREAM comes standard with studio-grade analog I/O on familiar, balanced XLR connections. And on the output side, ProSTREAM delivers fully processed, unencoded audio as well as encoded audio, giving you another source for processed sound. If you have an Axia Livewire™ network, hookup gets even easier: just plug ProSTREAM into a free Ethernet jack. Full network connectivity is provided via two Ethernet jacks, one for the LAN (which provides remote control and Livewire input) and the other for the WAN and sending encoded streams to your remote replication server.

## TOTAL CONTROL

ProSTREAM's intuitive Web interface provides remote control of all functions, including creation and editing of processing presets with an easy-to-use preset editor. Access your streaming controls anywhere, from any browser-equipped computer on your network. Of course, there are convenient front-panel controls too, so you can manage your most-frequently needed functions right from the rack.



## PROCESSING BY OMNIA



Optimizing sound quality is as essential on the web as it is on traditional formats. ProSTREAM has a built-in processing section that works together with the streaming encoder, optimizing your audio for stunning sound — even after bit-reduction. This isn't just some cheap leveler — it's real processing by Omnia, complete with wideband AGC, a 3-band combined compressor/limiter, high-frequency EQ, an adjustable-bandwidth low-pass filter, and Omnia's famous anti-aliasing final Look-Ahead limiter. There are even a selection of presets, tailored to specific formats and bit rates, to help you get up and running quickly. You've never heard streaming audio this good — until now.

## GENUINE FRAUNHOFER ENCODING



The foundation for high fidelity audio distribution rests on professional encoding technology. The quality of the encoder directly affects the quality of the output. Telos has a long history of partnership with Germany's Fraunhofer Gesellschaft Laboratory (FhG), the world leader in audio compression research and the inventors of MP3, and ProSTREAM uses genuine MP3 and MPEG-AAC encoding algorithms to ensure the most artifact-free sound quality at any bit rate you choose, from 16 kbps all the way to 320 kbps. No other encoder has this pedigree, or achieves this level of quality and performance. Generic "mp3" encoders can't come close.

## YOUR CHOICE OF CODECS

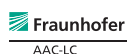

You've got your choice of genuine Fraunhofer encoding algorithms, which include MP3, the Standard for digital audio. It's the safest codec choice for compatibility with the widest variety of listening devices. AAC-LC, is a high performance codec for excellent audio quality at lower bitrates. AAC-LC is in widespread use, most notably in Apple's iTunes. And then there's High Efficiency Advanced Audio Coding, or HE-AAC, a newer AAC codec which incorporates Spectral Band Replication (SBR) bandwidth expansion to improve audio at very low bitrates. HE-AAC v2 applies a Parametric Stereo feature to HE-AAC codec allowing for even further reduction in bandwidth.

## SEND IT TO YOUR LISTENERS



When you're done processing and encoding, select your metadata source and feed your stream to any SHOUTcast or SHOUTcast v2-compatible media server, or a Wowza server for streaming to Flash clients. ProSTREAM works with ICast and Adobe Flash Media servers too, as well as the popular Live365 streaming service. You can feed directly to a streaming server on your LAN, to an Internet streaming relay service via the WAN port, or take processed audio from the rear-panel XLR outputs.

No matter what your audio source or how you stream, ProSTREAM delivers flawlessly optimized audio that sounds terrific.

## FEATURES AT A GLANCE

» Studio reference audio fidelity using genuine Fraunhofer MPEG-AAC and MP3 compression algorithms » Supports output bit rates from 16kbps to 320 kbps (dependent upon active codec) » Supports direct output to Wowza, ICEcast, Adobe Flash Media, Live365, SHOUTcast and SHOUTcast v2 servers. » Multiple metadata input templates include parsers for NexGen, Simian, iMediaTouch and Jazler radio automation software. More formats may be added easily via ProSTREAM's Web-based interface » Ensures the best-possible quality at the conversion stage with a pro-grade 24-bit A/D converter » Professional-grade I/O with both Livewire and balanced analog (XLR) inputs and outputs » Built-in webserver for remote control of all device

settings, plus mini stream-server for remote confirmation of audio presence and output » Front-panel controls include OLED display for in-person setup and process metering, plus ¼" TRS headphone jack with volume control » Three-band Omnia audio processing with wideband AGC, HFEQ, LP filter and look-ahead limiting » Separate LAN and WAN ports let you stream audio while keeping studio network isolated from the outside world » Multiple ProSTREAM devices can exist on the same network, allowing generation of multiple bit rates or streaming to different media server platforms » Best-in-the-industry 2-year warranty and access to the Telos 24/7 Support hotline -- radio never sleeps, and neither do we.

## FAQs

### I JUST WANT TO STREAM AUDIO OVER THE NET. WILL PROSTREAM DO THAT?

Yes, it will. Your audio goes in one end, and compressed, processed audio that's ready for the Internet goes out the other. All you have to do is send it to your streaming service provider.

### I WANT TO STREAM MY CHURCH SERVICE TO PARISHIONERS THAT CAN'T MAKE IT. WHAT DO I NEED?

It's quite simple actually. You need: 1.) An audio feed from your Mixing Console 2.) A Telos ProSTREAM Audio Encoder 3.) An account with a stream replicating company

### WHAT'S A "STREAM REPLICATING COMPANY"?

Companies like Wowza, Live365 and SHOUTcast are called "stream replicators" or "streaming service providers." Your ProSTREAM sends a single, fully ready packet stream to your streaming service provider. In turn the provider makes your stream available to dozens, hundreds, or thousands of listeners.

### I UNDERSTAND THE NEED TO ENCODE THE AUDIO BUT WHAT DO I NEED PROCESSING FOR?

Internet audio streaming without audio processing sounds thin and weak. Processing it makes a huge difference, and that's why Omnia audio processing is a part of ProSTREAM. You can use it to make sure that your encoded stream sounds as good as the original audio.

### CAN I STREAM TO ALL MY LISTENERS MYSELF, WITHOUT A STREAMING SERVICE PROVIDER?

Yes, this is possible, but requires specific knowledge of configuring and maintaining a separate server with replication software. It also requires outgoing bandwidth adequate to serve the

number listeners you expect. Most small businesses, radio stations, and individuals would not have adequate bandwidth to feed the number of listeners they'd like to serve. ProSTREAM users who wish to feed clients are successfully using SHOUTcast or ICEcast replication software, available for installation on Windows, OS X, and Linux platforms. Telos cannot provide support for replication servers. However, extensive information is available on their respective web sites.

### I ALREADY USE AUDIO PROCESSING ON MY WEB STREAM. IS YOURS REALLY THAT MUCH BETTER?

At the risk of sounding smug - yes! Omnia is the world leader in audio processing for radio broadcasting; you'll find Omnia audio processors on the world's most discriminating stations. The three-band Omnia processor built into ProSTREAM works arm-in-arm with the encoding DSP to deliver audio matched to the bit rate you've chosen - audio that sounds clear, clean and detailed, without the annoying "swirlies" that drive listeners to turn off Internet streaming. Other software encoders, if they have any pre-processing, have only basic EQ and perhaps some compression - not tools built exclusively to get the most from bit-reduced audio.

### CAN'T I JUST USE SOFTWARE INSTEAD OF HARDWARE TO DO THIS?

Sure you could. Omnia AX/E software from our sister company, Omnia Audio, lets you encode your audio content and send it to a Stream Replicator such as SHOUTcast or Wowza. But the advantage of ProSTREAM is that it eliminates the need for an extra PC to process and encode the audio for replication. Since ProSTREAM is a standalone box, you never have to worry about Windows updates or computer reboots.

## FAQs

### **I NOTICE THE DISPLAY IS QUITE CLEAR AND EASY TO READ, BUT WHAT IF I WANT TO ACCESS THE BOX FROM HOME?**

Every ProStream has a built in web interface to allow you remote access to the unit. You may change processing presets, type of codec, bitrate, etc., without ever having to drive to the station.

### **IF I CONNECT PROSTREAM TO MY NETWORK TO FEED AUDIO TO MY STREAM REPLICATOR, HOW DO I CONNECT TO PROSTREAM FOR REMOTE CONTROL?**

There are two Ethernet ports on each unit. One is designed for use within a LAN and the other for feeding to a stream replicator.

### **YOU MENTION THE WORD “ARTIFACTS” A LOT. ARE YOU REFERRING TO LOST HISTORICAL TREASURES?**

Well, no. The word “artifact” refers to changes in the audio that occur when it’s compressed into a digital format. High frequencies are commonly lost or distorted, and a swishy, swirly, water-like sound can be heard. ProSTREAM’s dynamics processing can reduce or, in most cases, totally eliminate digital artifacts so that your Web streams sound as good as your original audio.

### **WHAT ABOUT SONG TITLES OR OTHER INFORMATION? CAN THAT BE INCLUDED TO FEED TO THE NETWORK?**

Song title info or “metadata” can be passed through the ProSTREAM to provide details to the listener. There is a big list of default templates included, which are already formatted to work with the most common audio automation formats.

### **HOW DO I MONITOR THE FINAL PRODUCT, WHILE ADJUSTING THE PROCESSING IN A NOISY ROOM?**

You can do this remotely using the built-in Web browser or by using the headphone jack on the front panel. There is a volume adjustment knob there as well.

### **DOES PROSTREAM HAVE TO BE LOCATED AT MY SERVICE PROVIDER’S LOCATION?**

No. You can put it right in your equipment rack, with all your other gear. ProSTREAM sends its output to the streaming media server you specify, via LAN or WAN. The media server replicates the stream and sends it to Internet listeners. A typical application would have ProSTREAM at the studio, linked to your streaming replicator by a standard Internet connection, or something dedicated if you like.

### **HOW IS PROSTREAM BETTER THAN TYPICAL STREAMING SETUPS?**

Streaming from a PC can require two or three different pieces of software, or more. Trying to get all of that software to “play nice” can be something of a trial - as anyone who’s done it can tell you. ProSTREAM takes the place of separate software and PC encoders, putting everything into one pro audio appliance that’s easier to use, more reliable, and takes up less space than PCs (especially if you need a bunch of them in a rack). Also, there are no software licenses to maintain.

### **HOW MANY STREAMS CAN PROSTREAM PROCESS AT ONCE?**

Each ProSTREAM processes, encodes and delivers one audio stream per unit.

### **I NEED TO DELIVER SEVERAL STREAMS. CAN I ADD MORE THAN ONE PROSTREAM DEVICE TO MY NETWORK?**

Sure! You can stack as many as you like in your rack. Each bitstream, including the same program material at multiple rates, requires a unique encoder. So each ProSTREAM has a unique IP address for individual LAN control. Just plug in your audio and go! If you’re taking your inputs from a Livewire network, each ProSTREAM can subscribe to any available channel for processing and encoding.

### **CAN PROSTREAM CONNECT TO MY LIVEWIRE NETWORK?**

Yes, ProSTREAM can use any Livewire channel as its input, and can send its output back to the Livewire network too, if you like.

### **YOU MENTIONED THAT PROSTREAM HAS ITS OWN MINI STREAM SERVER. CAN I USE THIS TO SERVE MY STREAMING AUDIO TO LISTENERS?**

No, this mini server is not meant to service the hundreds or thousands of clients that a full-fledged media server can. It’s there so that you can listen directly to your Web stream, either in conjunction with remote control adjustments, or to confirm audio presence. (It also makes a handy private Internet “listen line” for PDs or other managers.)

### **HOW DOES PROSTREAM WORK AT LOW BIT RATES?**

You’ll be amazed at the quality of audio ProSTREAM delivers at even the lowest bit rates. Telos and Fraunhofer IIS (the inventors of MP3 and MPEG-AAC) have enjoyed a unique partner relationship for over two decades, and we use genuine FhG encoding algorithms to ensure the best audio quality possible, even at low bit rates.

## TELOS PROSTREAM SPECIFICATIONS

### AUDIO CODING

#### CODECS:

- MP3: 16 to 320 kbps
- AAC-LC: 24 to 320 kbps
- HE-AAC: 24-96 kbps
- HE-AAC v2 (aacPlus): 24-96 kbps

#### AAC TRANSPORT MODES:

- ADTS
- ADTS-CRC
- ADIF
- RAW

#### METADATA FORMATS:

- Character Parser Sample
- Line Parser Sample
- Nexgen Audio Sense
- Simian Template 1
- XML Parser Sample
- XML-Jazler
- XML-Jazler2
- XML-MediaTouch
- XML-MediaTouch2
- XML-Sample2
- XML-Zetta
- User-definable

### INPUT

- Analog: Balanced XLR, +4 dBu
- Input Impedance: 6K Ohm differential
- Analog to Digital Converter: 24bits
- Digital: Livewire AoIP, via LAN port

### OUTPUT

- Analog: Balanced XLR
- Output Clipping: + 22dBu
- Output Impedance: 50 Ohm differential
- Digital to Analog Converter: 24bits
- Digital: Livewire AoIP, via LAN or WAN port

### AUDIO PERFORMANCE

- THD+N: < 0.03% @ +12dBu, 1 kHz Sine
- Freq Response: +/- 1dB 25– 20 kHz
- Head Room: 18dB
- Dynamic Range: > 87dB Unweighted > 90 dB "A" Weighted
- Crosstalk: > 80 db

### REMOTE CONTROL

- LAN via built-in Webserver

### POWER

- Internal supply, 85–250 VAC auto-switching, 50–60 Hz.
- Power consumption: 14.2 Watts

### DIMENSIONS

- 19" (48.3 cm) standard rack mounting front panel
- 1.75" (4.5 cm) height, 6.5" (16.51 cm) depth
- Shipping Weight: 8 lbs. (3.62 kg)
- Shipping Dimensions: 24" x 14" x 6" (61 cm x 35.6 cm x 15.25 cm)

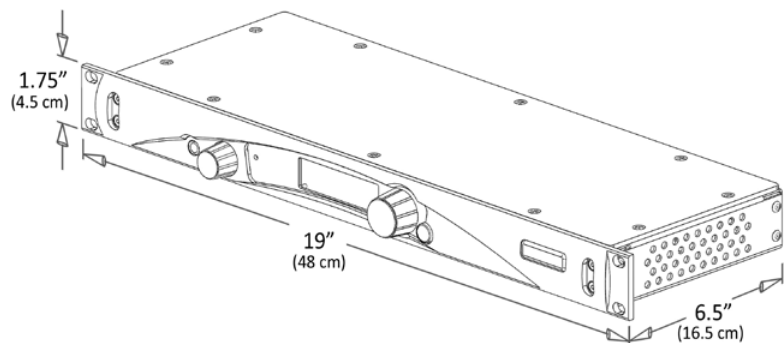

## ARCHITECTS SPECIFICATIONS

### SPECIFICATION OVERVIEW

The following describes an appliance for converting incoming audio to an optimized, standards-based real-time packet stream, suitable for localized or worldwide distribution over private or public IP networks. The resulting packet stream is intended for decoding into audio by popular hardware or software audio streaming clients.

The appliance shall be of a professional design, suitable for use by broadcasters, netcasters, and others requiring reliable, 24/7 unattended operation. The appliance shall feature professional audio inputs and outputs, multi-band audio processing specifically designed to optimize audio for bit-rate-reducing audio encoding processes, and a selection of popular, state-of-the-art audio coding algorithms for distribution at a wide selection of bit rates.

The appliance will also offer standards-based Audio over IP (AoIP) connectivity, convenient front-panel monitoring and basic configuration, browser-based remote monitoring and configuration, and a selection of meta-data filter templates to ingest audio metadata such as program, artist, and song title information, as well as other text and graphics URL messaging viewable by appropriate clients.

The appliance will afford both audio and streaming confidence monitoring via a front-panel headphone connection, rear-panel professional outputs, AoIP network stream, and self-contained HTTP streaming server. The appliance will also have provisions to send encoded audio streams to popular streaming servers such as SHOUTcast (both v1 and v2), ICEcast, Wowza, and Adobe Flash Media Streaming Server.

### PHYSICAL

The appliance shall consist of a 1RU, 19" standard rack-mount enclosure. The front panel shall be an attractive, yet functional design with a bright, clear OLED-based display, combination navigation/selection rotary encoder, "back" or "ESC" button, headphone jack, and headphone volume control. The appliance shall be quiet in operation, fanless, and connect to AC power via an IEC power entry module. AC power input shall be of universal design, accommodating worldwide standard AC power voltages and frequencies.

The rear panel shall provide analog audio inputs via two XLR-F bulkhead connectors for Left and Right audio, and analog outputs on two XLR-M bulkhead connectors for Left and Right audio. An optional AES3 audio input and output card, mounted internally, shall supersede analog I/O functionality, if installed, and provide AES3 standard digital audio I/O. All audio inputs, outputs and streams shall be stereo.

The rear panel shall provide two Ethernet/IP (network) connections on standard RJ-45 bulkhead connectors.

### AUDIO INPUT, OUTPUT, AND PROCESSING

The appliance shall offer analog (and optional AES3) audio input and output with software-selectable audio I/O levels to accommodate professional broadcast equipment connections.

The appliance shall offer multifunction, multiband audio processing for the purpose of normalizing incoming audio levels, processing such audio for desired clarity, texture, tonal balance, and loudness, and provide best-practice, intelligent look-ahead limiting for precise level control. The appliance shall provide for factory-supplied audio processing presets, editing of presets to create user presets, and convenient save and recall of presets.

Processed audio shall be delivered internally to the encoding section of the appliance, as well as available externally via the XLR-M audio outputs and AoIP (Livewire) output. The AoIP audio I/O functionality shall be fully compatible with the Livewire AoIP standard.

### ENCODING AND TRANSPORT

The appliance shall perform audio bit-rate-reduction via a selection of industry-standard, psychoacoustic algorithms. Specifically, the appliance shall offer MP3, AAC-LC, HE-AAC, and HE-AAC v2 audio coding algorithms. The appliance shall offer target bit rates from 14 to 320 kbps, depending upon the algorithm selected.

For AAC-based streaming algorithms, the appliance shall offer a selection of "transport containers" including ADTS (default for most uses), ADTS-CRC, ADIF, and RAW formats.

### METADATA

The appliance shall offer configuration for ingest of formatted metadata or use of static metadata, either of which shall be combined with the streaming audio data for ultimate use by the streaming client. The appliance shall include default templates for several common broadcast automation data formats. Each of the templates shall be modifiable to suit any changes needed, or new templates may be created. Metadata templates shall be selectable via the front panel or via the web interface. The appliance shall include a metadata parser, which will use the selected template to determine the incoming data contents, and then update the audio stream metadata.

### STREAMING SERVERS

The appliance shall support several popular streaming servers including SHOUTcast (both v1 and v2), ICEcast, Wowza, and Adobe Flash Media Streaming Server.

## ARCHITECTS SPECIFICATIONS

The appliance shall be capable of sending the same stream to up to four (4) disparate SHOUTcast, ICEcast, Wowza, Live365 and other servers simultaneously, thus offering functional and/or geographical redundancy. The appliance shall also offer inbuilt HTTP “pull” streaming for local or remote confidence monitoring, or for alternate streaming to other servers such as Wowza.

### **NETWORK SUPPORT**

The appliance shall support two self-contained Ethernet/IP network interfaces. Each network connection operates independently, each having its own MAC address, and may be individually assigned an IP address and other standard networking parameters. Either connection may be used for remote control, monitoring, and streaming. One of the connectors may also be used for AoIP (Livewire standard) audio I/O.

### **SYSTEM UPDATES**

The appliance will allow two versions (banks) of operating software to be stored internally. The appliance shall support the updating of its operating software via standard web browser access and file upload. The appliance shall further support web or file-based software updates with selection of booting to either software bank.

### **SUPPORT AND WARRANTY**

The appliance shall be offered with a standard limited warranty period of two years. English-language factory support shall be available to users at no charge on a 24/7 basis.