

# WHEATSTONE PROCESSING

OVERVIEW/PRODUCT PLANNING GUIDE



**VORSIS**

ULTRA HIGH RESOLUTION PROCESSING



**Wheatstone**

**VORSIS<sup>®</sup>**

ULTRA HIGH RESOLUTION PROCESSING

Wheatstone believes that you should have the power to shape your OWN sound – one with a completely unique sonic signature that’s your sound, not the one created by a processor manufacturer. To achieve this goal Wheatstone has developed Vorsis Ultra-High Resolution Processing technology to provide completely clean, high quality ‘draw you in’ sound that even the best ears in the business love to hear. This proven Vorsis technology is embedded in every Wheatstone processor to create the cleanest sound, as loud as you want it.

To get there, it required taking a completely fresh approach to processing. Vorsis Dynamics Control (AGC and compression) employs multiband AGC to ensure consistent spectral balance. Its Multiband Compressor works with the AGC to provide unprecedented dynamics control.

The Vorsis Bass Management System (VBMS) extracts and reveals nuances in the program to deliver pristine, deep, distortion-free bass over the air. No other processor delivers bass this bold and clean.

Vorsis’ Superior Stereo Enhancement is integral to the processing and creates a smear-free perception of a wider sound field in the cleanest possible way. Just stunning.

Our limiting and clipping are, bar none, the finest you’ll ever use. Up to 31-bands ensure surgical precision and the ability to have the cleanest, loudest signal on the dial.

Vorsis’ presets are also some of the best in the world. You may never need to tweak them, but if you do, our Graphical User Interface, whether via the front panel or accessed by a PC, gives you an intuitive toolset that’ll make you feel right at home.

We think Wheatstone’s Vorsis Ultra-High Resolution Processing is the best you’ll ever use. But don’t take our word for it. Try it out. We CAN guarantee you’ll be happy you did!

# VORSIS TECHNOLOGY

Ultra High Resolution Processing

## Modern Ears Want Modern Audio:

It's no secret that radio has sounded tired for a very long time now. With modern delivery options, exciting new technology and our brains buzzing with fresh ideas about how to use it, Wheatstone thinks it's time to for processors that work in unique new ways to make radio sound better than ever - WAY better. Wheatstone's Vorsis tools help you get the most out of your content, whether it's a minor bass adjustment or a format change requiring an entirely new sound. It's a new audience and Vorsis gives today's engineers a modern audio toolbox (a treasure chest, actually) for great sound. Contact Wheatstone for a free in-station demo - listen and see if you don't agree that it's a hugely positive difference whose time has come.

## SST:

SST, which stands for Sweet Spot Technology, is a different approach to audio level control in an audio processor. SST operates through a proprietary technique called Density Compensation™.

This algorithm utilizes real-time analysis of the pre and post-processed audio, and data from the processing controls as the user has adjusted them, to invisibly manage the user set spectral balance and program density. The result is the replacement of the traditional wideband AGC with a device that is smart and truly sentient about audio management. SST can be found in our flagship AirAura X3 FM & HD audio processor and in our FM-531HD audio processor.

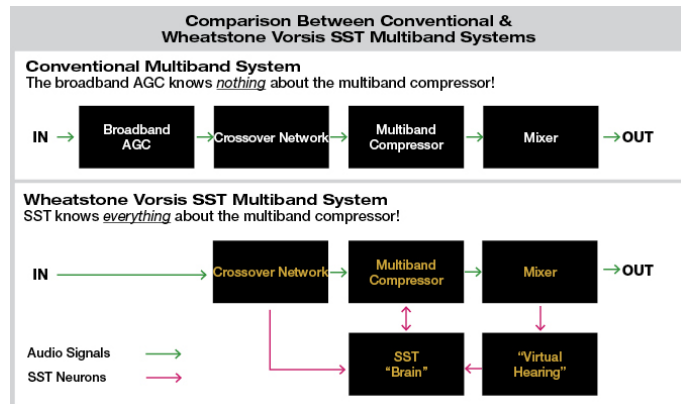
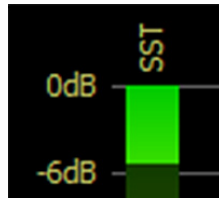

## Bass Tools/VBMS:

Bass Tools is another Wheatstone Processing exclusive designed to achieve a level of smoothness in bass not possible with other bass enhancement systems. Enhancement is done in conjunction with our 31 band limiter system. The Bass Tools platform is side-chained so you can easily create the type of bass you want and then mix it back into the main program signal. This way, the bass is accurate and consistent, and since it is well controlled, does not add any amplitude to the overall signal. Available as VBMS in the FM-4, VP-8IP and AM-10HD. Available as Bass Tools in the FM-531HD and AirAura X3.

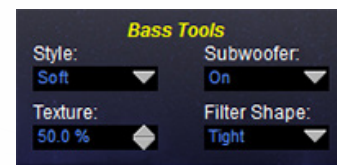

## SQ (Super Quiet) Mic Preamps:

Found in our M1, M2 and the new M4-IP Microphone Processing BLADE, our SQ mic preamps ensure that the audio of your talent begins its journey to your listeners in the cleanest environment available. Wheatstone has taken its 30 year history of clean console microphone preamps and married it with Vorsis Processing Tools for EQ, Expansion, Compression and De-Essing for mic processors that have quickly become the industry standard.



## Adaptive Filter Banks:

An exclusive to our AM-10HD audio processor, this Vorsis Processing tool automatically rescales the multiband limiter in the AM-10HD based on the bandwidth setting you select for transmission. No longer do you need to "throw away" 2 or 3 bands of a processor when you choose a lower bandwidth; the AM-10HD ensures you get the maximum benefit of our multiband limiter regardless of the bandwidth needed.

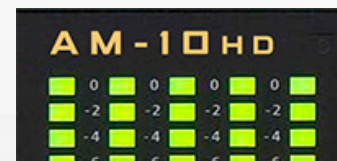



**31 Band Limiter:**

Another exclusive to Wheatstone Audio Processing is our 31 band limiter, found in our AirAura X3 FM and HD audio processor and our FM-531HD audio processor. Championed in our legacy AP2000 processor, the 31 band limiter takes advantage of the way humans hear to limit audio in very few bands at a time. The result? Pinpoint accuracy, audio limiting focused only where needed and an overall audio signal that, at any given time, actually has LESS limiting going on than any other processor on the market. Other cool features? The 31 band limiter can be run in Wide (10 band mode) or Wide & Timbral (where the limiters auto-adjust between 5 and 10 band mode depending on content) or Timbral (where the limiters will adjust to deal with harmonics in the limiter and not in the clipper).

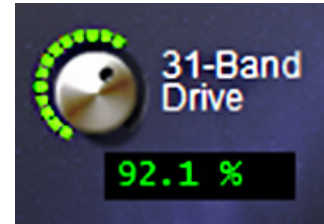

**Multipath Limiter:**

The Multipath Limiter is a feature designed to create predictable stereo enhancement from source to source and avoid excessive L-R (difference) transmission. Used in our FM processors (FM-4 excluded), the Multipath Limiter allows the end user to limit the maximum amplitude of the L-R signal as a percentage of the L+R signal. The end result helps reduce multipath blend (think car stereos).



**WheatNet-IP:**

Every time you turn around, another Wheatstone Audio Processor is streaming audio using WheatNet-IP. First available in the AirAura2.0, Wheatstone Audio Processors using WheatNet-IP now include AirAura X3, FM-531HD, VP-8IP, Aura8-IP Audio Processing BLADE and the M4-IP Microphone Processing BLADE. WheatNet-IP allows you to easily manage audio to and from your processors, adding the power of Vorsis Processing Tools to your entire IP audio network and making them just as flexible as your WheatNet-IP surfaces and controllers!



**Analysis Tools:**

Now it's easy to SEE what you're hearing. Vorsis Analysis Tools give you the ability to visualize the audio created in your processor. For the FM-531HD, these tools include an FFT display as well as our popular 3D Time v Frequency v Amplitude display and many others. For AirAura X3, these displays are expanded upon to show MPX analysis of your AirAura processing as well as giving you the option of inserting an external source to display.

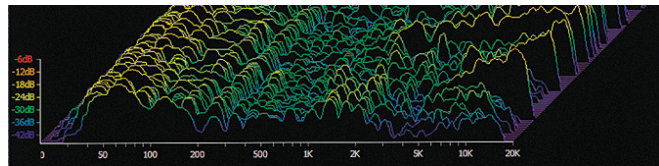

**GUI Guru:**

Each Wheatstone broadcast audio processor comes packaged with our powerful GUI Guru software. It's as if we sent a processing expert with each box! GUI Guru makes the tough behind-the-scenes decisions based on the simple to use controls supplied for AGC, Compression, Density, Loudness and Bass and Treble controls. Available for the FM-4, VP-8IP (all modes), FM-531HD and AirAura X3 audio processors.



**Wheatstone® baseband192:**

Wheatstone® baseband192 digitizes the entire multiplex spectrum up to and including the RDS, doing away with an analog composite interface between processing and transmission.

A single AES/EBU cable carries the digitized signal between the FM-531HD and any FM transmitter equipped with a digital baseband input, bypassing the need for multiplexing in the exciter and eliminating the resulting signal overshoot and its associated loudness tradeoff. The baseband192 interface is a standard feature in Wheatstone FM-531HD, AirAuraX3, and VP-8IP audio processors.

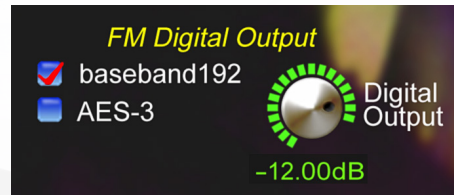

# AIR Aura X3

Digital Spectral Audio Processor



Being loud just to be loud is easy. It's been easy for years. Turning up the volume without causing listener fatigue – that's the real challenge. X3 technology inside our AirAura delivers that sought-after loudness without ever sounding harsh, clipped, distorted or overdone. It simply sounds real.

The AirAura X3 spectral audio processor for FM is equipped with processing technologies that simply didn't exist until now, starting with a new final clipper that creates extremely competitive loudness while also minimizing listener fatigue. Another new technology unique to our NEW third-generation AirAura helps extend perceived stereo coverage, and yet another technology helps hide the annoying coding artifacts that might be present in a station's stereo source material.

AirAura X3's incredible dial presence, three selectable stereo multiplex modulation methods, the ability to help mask coding artifacts, and its mitigation of many stereo multipath annoyances as well as its exclusive clipper technology make it THE processor for on-air FM.

### AirAura X3 Distortion-Managed Final Clipper

AirAura X3's has an entirely new final clipping technology that does two things very well: loud and clean. Simultaneously. Its new final peak clipper is based on proven VORISIS technology that does not generate the objectionable aliasing and intermodulation distortions commonly associated with less-complex clipper technology. The result is squeaky clean audio, even at extremely competitive loudness levels. AirAura utilizes high resolution distortion recognition algorithms to discern audio from distortion. The fine-grained selectivity afforded by this technology is the best way to sense and truly mitigate distortion. Other technologies can only make a "best guess" at separating desirable audio components from undesirable distortion products.

By analyzing the audio and the distortion products created during peak control, AirAura removes distortion products and other artifacts that a listener might find objectionable. It is highly adept at minimizing intermodulation distortion, especially close-spaced difference frequency intermodulation products in the midrange frequencies where human hearing is the most sensitive.

During beta testing in major markets listeners commented about how smooth and open the entire audio spectrum sounded when processed by our new AirAura clipper. Achieving effortless competitive loudness on the air while remaining subjectively cleaner than their usual on-air processor was never an issue. In fact, in one top-ten market we were actually asked if we could "turn it down just a little bit."

### AirAura X3 PostCode Tool

Some audio processors precondition audio to make it more favorable for a codec's input, but no on-air processor had ever been developed with features specifically designed to help already coded stereo audio sound better after the fact. That is, until now.

AirAura X3's all-new PostCode Tool™ helps minimize the audibility of coding artifacts in stereo program material without degrading the overall listening experience. By reducing the swishing, swirling, grainy artifacts of coded audio, the AirAura X3 enables listeners to listen as long as they like with no fatigue.

### AirAura X3 “Fine Grain” Processing

The AirAura X3 has an entirely new algorithm for selectively processing only those frequencies that need processing, which overcomes the limitations of peak limiters in other on-air processors. Using 31 limiter bands selected according to ISO standard 1/3 octave center frequencies, the AirAura limiters (one for FM, one for HD) perform precision spectral energy control without generating additional density or artifacts usually associated with peak limiters having fewer bands. Operating according to accepted principles of human psychoacoustics, the action of the limiter goes completely unnoticed by the ear. Because of the need for very shallow limiting in each band, there are absolutely no ‘swishing’ artifacts and no unnatural density buildup; just increased on-air loudness, detail, and “listenability” of the station’s programming.

### AirAura X3 five-band Sweet Spot AGC

AirAura X3 has an entirely new Sweet Spot Technology (SST) that effectively manages the behavior of the multiband AGC as program content density changes, something a typical broadband AGC simply cannot do. It effortlessly handles transitions between the hyper-compressed recordings of today and those of the past that have considerably more dynamic range. SST achieves uncannily natural-sounding consistency in both on-air loudness and spectral balance regardless of density variations in the incoming source material.

### AirAura X3 Vorsis Bass Management System

AirAura X3 has a new and better Vorsis Bass Management System (VBMS) with new tuning features that enhance deep bass without affecting the cleanliness of mid and high frequency program. Bass detail and the clarity of higher frequency audio are enhanced by this more powerful algorithm. If you thought second-generation AirAura bass was something, you will be amazed at the deep and natural sounding bass coming from the AirAura X3.

### Exclusive Multipath Control

Exclusive to the Wheatstone line of audio processors is the Multipath Limiter. This single user control can help mitigate the audible effects of multipath as well as reduce receiver-induced stereo blend by limiting the amount of L-R as a percentage of L+R for a more consistent and predictable sound.

### AirAura X3’s Smarter Stereo Enhancement

Operating in the sum and difference domain and utilizing specialized spectral management algorithms, AirAura’s Smart Stereo Enhance provides a smooth, natural, wide listening experience without triggering multipath effects. It delivers an extremely stable ‘on-air’ stereo image that’s exciting to listen to. Users have reported hearing, for the very first time, artistically important nuances in familiar music that could not be heard when that material was processed by other on-air processors.

- New final clipping technology – very clean and very loud – simultaneously
- New Five-band AGC with Sweet Spot Technology tuning capabilities
- New codec artifact reduction algorithm helps tame coded stereo source material
- New 31-band limiter algorithms
- New left/right analog output routing for FM and HD processing
- New equalizer offers both parametric and Baxandall-style shelving EQ
- New bass management system with enhanced tuning features
- New high performance stereo generator with DSB and two SSB encoding methods
- New Guru GUI tuning capabilities
- New advanced analysis features for displaying internal and external signals
- New comprehensive security features designed for mixed-use sites
- New post-processed loudness analysis conforms to BS-1770-S standards
- New preset storage for up to 160 processing presets
- Analog, digital and WheatNet-IP audio I/O with automatic ‘failback to primary’
- Exclusive stereo multipath controller technology for enhanced stereo reception
- Remote processor control via wired Ethernet or integrated Wi-Fi connectivity
- Specialized audio analysis functions for input or processed audio include:
  - 1,024 point FFT
  - Oscilloscope
  - Energy versus Frequency
  - 3-D plot of spectral content vs. time
  - vSpectral Dynamic Range (a Vorsis exclusive)
  - Display of AirAura’s clipper distortion masking activity
- WheatNet-IP compatible
- Wheatstone® baseband192 built in for digital link to transmitter



# FM-531 HD

High Definition Audio Processor



Our FM-531HD on-air FM processor has everything our flagship AirAura processor has for squeaky-clean audio and bass that rocks, but in a 1RU package and at a very budget-friendly price.

Our FM-531HD is a 1RU on-air processor for FM/HD use. Packaged in a compact, 1RU form factor, this processor brings the multiband precision of our flagship AirAura® processor to a budget-friendly price point. Its Vorsis Ultra High Resolution processing technology delivers superb on-air sound that's loud, yet detailed.

Features include a distortion-managed final clipper for squeaky-clean audio, smart stereo enhancement, bass management for deep, yet clean bass, and Sweet Spot Technology for consistent sound regardless of density variations in the source material.

### Distortion-Managed Final Clipper

The technology utilized in our FM-531HD final peak clipper does not generate the objectionable aliasing and intermodulation distortions commonly associated with less-complex clipper technology.

Similar in certain ways to our acclaimed 31-band 'Fine Grain' limiter (a Vorsis exclusive), the FM-531HD utilizes high resolution distortion recognition algorithms to discern audio from distortion. The fine-grained selectivity afforded by this technology is the best way to sense and truly mitigate distortion. Other technologies can only make a "best guess" at separating desirable audio components from undesirable distortion products.

By analyzing the audio and the distortion products created during peak control, the FM-531HD removes distortion products and other artifacts that a listener might find objectionable. It is highly adept at minimizing

intermodulation distortion, especially close-spaced difference frequency intermodulation products in the midrange frequencies where human hearing is the most sensitive.

### "Fine Grain" Processing

"Fine Grain" processing overcomes the limitations of peak limiters in other on-air processors. Using 31 limiter bands selected according to ISO standard 1/3 octave center frequencies the FM-531HD limiters (one for FM, one for HD) perform precision spectral energy control without generating additional density or artifacts usually associated with peak limiters having fewer bands. Operating according to accepted principles of human psychoacoustics, the action of the Stealth Limiter™ goes completely unnoticed by the ear. Because of the need for very shallow limiting in each band, there are absolutely no 'swishing' artifacts and no unnatural density buildup; just increased on-air loudness, detail, and "listenability" of the station's programming.

### Sweet Spot Technology

Sweet Spot Technology (SST) has been designed by Vorsis to manage the behavior of the multiband AGC as program content density changes, something a typical broadband AGC simply cannot do. It effortlessly handles transitions between the hyper-compressed recordings of today and those of the past that have considerably more dynamic range. SST achieves uncannily natural-sounding consistency in both on-air loudness and spectral balance regardless of density variations in the incoming source material.



### Vorsis Bass Management System - v2.0

The Vorsis Bass Management System (VBMS) enhances deep bass and impact without affecting the cleanliness of mid and high frequency content. Bass detail and the clarity of higher frequency audio are enhanced by this powerful, innovative algorithm. With VBMS' 'Texture' and 'Sub' controls, on-air bass has never sounded so good and so deep and natural.

### Exclusive Multipath Limiter

Exclusive to the Wheatstone line of audio processors is the Multipath Limiter. This single user control can help mitigate the audible effects of multipath as well as reduce receiver-induced stereo blend by limiting the amount of L-R as a percentage of L+R for a more consistent and predictable sound.

### Smart Stereo Enhancement

Stereo enhancement is a standard feature on all Vorsis on-air processors and utilizes a Vorsis technology: Smart Stereo Enhancement. Operating in the sum and difference domain and utilizing specialized spectral management algorithms, it provides a smooth, natural, wide listening experience without triggering multipath effects. It delivers an extremely stable 'on-air' stereo image that's exciting to listen to. Users have reported hearing, for the very first time, artistically important nuances in familiar music that could not be heard when that material was processed by other on-air processors.

- Distortion-managed final clipper for squeaky clean audio
- 31-band limiting for precision spectral energy control without generating additional artifacts typically associated with fewer bands
- Exclusive SST technology for sound consistency regardless of density variations in the incoming source material
- Bass management technology for deep bass without affecting the cleanliness of mid and high frequency program
- Exclusive Multipath Limiter for mitigating the effects of multipath
- Smart stereo enhancement for extremely stable 'on-air' stereo image that's exciting to listen to
- Audio Processing Guru® GUI included standard
- Five band phase linear adjustable crossover feeding a five band AGC
- Exclusive 31-band limiter technology
- Exclusive VBMS™ (Vorsis Bass Management System)
- Selectable FM peak control via oversampled lookahead limiter or distortion masked clipper
- Four band full parametric equalizer
- Variable high pass filter
- Voice phase rotator
- AES3 digital input accepts 32kHz - 96kHz
- AES3 digital output automatically synchronizes to AES3 digital input
- WheatNet-IP compatible
- Wheatstone® baseband192 built in for digital link to transmitter

# VP-8IP

Multi-Mode Digital Audio Processor



The Wheatstone VP-8 IP multimode audio processor gives the cost/performance envelope a nice upward push. VP-8 IP, the broadcast industry's first multi-mode broadcast audio processor, is equipped with six built-in and highly specialized independent processing functions. AND it ties directly into the WheatNet-IP Intelligent Network which greatly increases its flexibility.

The VP-8 IP incorporates six highly specialized, built-in processing modes that may be changed at any time by the user.

Special processing algorithms designed by Wheatstone condition the audio appropriately for the special needs of each of the six operating modes. Audio is first pre-processed by a phase-linear four band AGC followed by an eight band multi-band limiter equipped with special mode-specific final processing. The final processing algorithms are unique for each mode and have been carefully designed to meet the special requirements of the intended audio transport mediums.

The VP-8 IP architecture includes processing for FM (with built-in reference grade stereo generator and inputs for SCA or RDS), AM/AM-Stereo, and four specially optimized processing modes. These four modes have been specially designed and tuned for the challenges of codec-based mediums such as FM-HD, AM-HD and low bitrate applications using the MP3/AAC codecs.

Regardless of the operating mode, the VP-8 IP offers the best listening experience of any audio processor in its price range. The VP-8 IP's built-in library of algorithms specifically addresses the special needs of FM, AM, FM-HD, and AM-HD, as well as High and Low bitrate codec applications.

## Vorsis Bass Management System

A Vorsis innovation, the Vorsis Bass Management System (VBMS) circumvents bass-related distortion often plaguing audio processors. By monitoring program energy in the audio spectrum and manipulating the behavior of the final peak limiter, bass-induced intermodulation distortion is prevented. The result is improved bass impact and detail without affecting the clarity of mid and high frequency program -- in fact bass detail and the clarity of higher frequency audio are actually enhanced by the VBMS algorithm.

## Exclusive Multipath Limiter

Exclusive to the Wheatstone line of audio processors is the Multipath Limiter. This single user control can help mitigate the audible effects of multipath as well as reduce receiver-induced stereo blend by limiting the amount of L-R as a percentage of L+R for a more consistent and predictable sound.

## Smart Stereo Enhancement

The VP-8 IP incorporates a new technology that we call Smart Stereo Enhancement. Operating in the sum and difference domain and under the management of specialized automatic level and spectral management algorithms, the resulting stereo image is wide and acoustically stable with no 'hole in the middle' effect. Producing a sound that has great depth of detail and is exciting to listen to, artistically important nuances in music can be revealed for the very first time. In fact, Wheatstone customers have reported hearing details in program material that were completely inaudible when the same material was processed by other brands of audio processing.



### VP-8 IP Software GUI

Basic setup is via VP-8 IP AUDIO PROCESSING GURU® Software. Install it on a Windows® PC, and connect to the VP-8 IP directly, over a network, or over the Internet.

Audio Processing Guru® Software gives you six easy to understand controls to customize any preset. Each control changes multiple parameters behind the scenes to ensure intelligent adjustments to your sound. It's like having your own audio guru with you when you tweak!

Selecting a new processing mode is as simple as selecting it from the front panel or from within the Windows®-based Graphical User Interface. Mode changes occur in less than two seconds, with no reboot or 'memory bank selection' being required in order to change the VP-8 IP to a completely different processing mode.

Remote control is via 100BaseT wired Ethernet and Windows®-based GUI software. Additionally, the VP-8 IP can be located anywhere on Wheatstone's WheatNet-IP Intelligent Network for direct access from any WheatNet-IP compatible device.

- Switchable for FM analog, FM-HD, AM analog, AM-HD, Streaming >48kHz, Streaming <48kHz
- Updated preset library with dozens of factory processing presets separately designed for each medium, carefully tailored to get you sounding great quickly
- VBMS™ Vorsis Bass Management System for clean, deep, low bass without the typical distortions
- Front-panel metering of input levels, output levels, and processing activity
- FM stereo generator/encoder
- Stereo enhancement
- Diversity delay for HD
- Test/setup oscillator
- Headphone monitoring of each processing stage
- Front-panel control for selection of presets and setup; can be locked out for security
- Built by Wheatstone in the United States
- WheatNet-IP compatibility
- Wheatstone® baseband192 built in for digital link to transmitter

# AURA8-IP BLADE

Vorsis Eight-Channel Audio Processing BLADE



Placing a processor everywhere you'd like one has been costly and impractical. Until now. A single Aura8-IP gives you up to eight processors to use as you wish. Use it as a standalone processor with analog and digital inputs or make it a part of your WheatNet-IP network. Either way, the Aura8-IP is a powerhouse.

The Aura8-IP occupies a single rack space, but packs an impressive complement of eight fully independent Vorsis® multi-band stereo audio processors. Each processing chain consists of a 4-band parametric equalizer followed by a crossover and three bands of compression. The compressors each feed their own limiters, whose outputs are then fed to a broadband lookahead limiter for tight peak control. The Aura8-IP has its own local I/O, with four stereo pairs of AES digital audio and four stereo pairs of analog line level audio in and out, and can function as a standalone processing engine. Because it's a BLADE, it can also instantly configure itself as part of a new or existing WheatNet-IP Intelligent Network, making its processing power available throughout that network.

The Aura8-IP is configured and controlled over Ethernet using a laptop or desktop computer. Included with the unit is Wheatstone's acclaimed "Audio Processing GURU" software, which allows easy setup of the processing using familiar, straightforward controls. Also available is a more sophisticated control interface called "GUI Pro," which provides access to every individual processing parameter for expert-level adjustments.

As with all BLADES, a routing matrix and routing control interface are included as well as two 8-channel stereo utility mixers which can be controlled by WheatNet-IP Navigator software or by the Sideboard control surface, and can be used for a wide range of applications.

The Aura8-IP also has a built-in web server, so you can configure and control locally or remotely without having to run dedicated software. There's flexible GPI logic with 12 universal logic ports, programmable as inputs or outputs and routable throughout the entire system, SNMP messaging for alerts, and silence detection on each output that can trigger alarms or make a routing change.

- Highest performance 24-bit A/D and D/A convertors
- 8 complete Vorsis multiband processors, each with:
  - 4-band parametric equalizer
  - 3-way crossover
  - 3 compressors
  - 3 limiters
  - Final lookahead limiter
- Two 8-channel utility mixers
- 4 AES digital inputs on RJ45 and "D" connectors
- 4 stereo analog inputs on RJ45 and "D" connectors
- 4 AES digital outputs on RJ45 and "D" connectors
- 4 stereo analog outputs on RJ45 and "D" connectors
- Built-in router control
- Front panel headphone jack
- Socketed Output Chips
- Front Panel Metering
- Rugged Power Supply
- Can be used standalone or as part of a WheatNet-IP Intelligent Network
- Silence sensing can be applied to any outputs
- One Gigabit Ethernet port



What can you do with the Aura8-IP? Virtually anything you want! These are just a few of the ways you might use Aura8-IP. As a standalone processor, you get eight stereo channels of jaw-dropping VORSIS ultra high resolution processing power for under \$500 per channel. That alone is worth the price of admission. But when you take advantage of Aura8-IP being a BLADE with its built-in utility mixers, web server, full logic, SNMP messaging and silence detection, and use all that with it's 8-channels of processing, its power is really unleashed. How many ways can YOU think of to use the Aura8-IP?

**Low Latency Talent Headphone Processing**

Often, the key to talent turning in their best performances is what they hear in their headphones. Give them a sound that drives them to brilliance with Aura8-IP.



**Remote Feed Conditioning**



The great and hard thing about radio is that you can tie the world together on your broadcast. That means you can have audio flying in from all over. Aura8-IP is exactly what you need for all of it, at a price that will make you very happy!

**Talkshow Call-Ins**

Processing can make a huge difference in the on-air quality of call-ins on your talk shows. Aura8-IP is up to the task.



**Mic Processing**

Every microphone does a better job when it's processed not only for the voice that's speaking into it, but for the path it's taking on the way to someone's ears. Aura8-IP does a superb job processing microphone audio.



**Satellite Uplink Peak and Spectral Control**

The key here is keeping signals under control. Aura8-IP is perfect for the job, keeping an eye (or ear) on the peaks as well as ensuring the spectral range stays consistent.



**IFB Conditioning**

Clear communications between director, engineering and talent is key to presenting successful sports and multiple-report shows. Aura8-IP is perfect for cleaning up IFB.



**STL Pre-Processing and Protection-Processing**

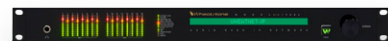

There are a lot of dedicated STL systems out there. Or, if you have a WheatNet-IP, it's the perfect solution. No matter HOW you handle STL, let Aura8-IP handle processing to ensure the audio is optimized for it.

**Multiple HD Feeds**

HD Radio gives you the option of broadcasting multiple audio streams of varying quality. Make the most of each by giving them processing that will make them stand out.



**Sweetening Incoming Commercials and Newsroom Feeds**

Keeping your revenue sources sounding compelling can really help with audience perception and acceptance. Aura8-IP is a cost-effective solution for ensuring your entire audio stream sounds SWEET!



**Codec Pre-Processing**



Audio from codecs is subject to environmental conditions - at the source and through the connection. Processing with Aura8-IP can clean it up nicely.

**Web Streams**

Whether you are streaming now or getting ready to, there's no better investment you can make in your station than to ensure those streams sound great. That's exactly what Aura8-IP does.



**Automation Streams**

Wheatstone enjoys technology partnerships with the leaders in broadcast today. Use the AGC in Aura8-IP to keep your automation streams clean and under control.



# FM-4

FM Audio Processor



Sound and simple. The FM-4 digital audio processor has Vorsis engineering inside for great sounding on-air programming, but without all the frills. This FM audio processor is simple and affordable, yet powerful and capable where it counts. The FM-4 is equipped with a reference grade stereo generator, as well as analog, digital, and SCA/RDS inputs, and has those sought-after Vorsis features such as smart stereo enhancement and knock-your-socks-off bass.

For the budget-conscious broadcaster who still wants the benefit of the very latest in broadcast audio processing technology, the FM-4 is an ideal choice. Possessing the same processing tools as its larger brethren but with fewer bands, the FM-4 gives even the smallest station the power to improve its loudness and clarity with that sought-after Wheatstone sound. Front-panel setup ability and a variety of built-in I/O make the FM-4 at home in any air chain.

The FM-4 owes its heritage to the highly successful six-mode VP-8. We've re-packaged and realigned many of its best features to create an FM-only processor that fits even the tightest of budgets, yet is more than competitive enough for the most demanding medium and small markets.

Ideal for stations looking for no-frills FM-only audio processing while enjoying Wheatstone's superior Vorsis technology, the FM-4 offers everything you need to create your signature sound. The FM-4 gives you the out-of-the-box presets Vorsis is famous for, conveniently accessible right from the front panel. And you can give those presets your own spin with the included Audio Processing Guru® GUI software. Plus, it's fast and easy to integrate into your station, with analog and digital I/O, an analog MPX output, an AES digital output and an SCA input. Four limiter bands get you the performance you need at a cost you can easily afford.

Summing it up, in a few words – simplicity and great sound. That's all it takes to give you exactly what you need to make your FM station sound great.

## Vorsis Bass Management System

The Vorsis Bass Management System (VBMS) circumvents bass-related distortion plaguing other broadcast audio processors. The result is increased bass impact and detail without affecting the clarity of mid and high frequency program -- in fact bass detail and the clarity of higher frequency audio are actually enhanced by the VBMS algorithm.

## Smart Stereo Enhancement

Stereo Enhancement is a common feature in audio processors today. However our approach is a new technology we call Smart Stereo Enhancement. Operating in the sum and difference domain within the multiband AGC and under the management of specialized automatic level and spectral management algorithms it provides a wide but extremely stable 'on-air' stereo image. "Wide", "alive", "exciting to listen to", and "very natural sounding" are terms customers have used to describe how our enhancement method sounds. Many users have reported hearing artistically important nuances in music that were simply inaudible when the same material was processed by competing products.

## Audio Processing Guru® Software

Processing is as much art as science. If you're more artist than scientist and have trouble keeping track of the dozens and sometimes hundreds of controls that modern processors offer, Audio Processing Guru® software will be the key to happiness. It condenses the functions of the various processor controls down to just a few, easy-to-understand sliders, enabling you to concentrate on what you hear, not what you see.



- Four band phase linear adjustable crossover feeding a four band AGC
- Four band phase linear crossover feeding a four band limiter
- Exclusive VBMS™ (Vorsis Bass Management System)
- FM peak control via oversampled lookahead limiter or distortion masked clipper
- Four band full parametric equalizer
- Variable high pass filter and voice phase rotator
- Ethernet-based remote control via 100BaseT Ethernet and rear panel RJ-45
- Eight input GPI preset triggers
- AES3 digital input accepts 32kHz - 96kHz
- AES3 digital output automatically synchronizes to AES3 digital input
- Precision FM stereo MPX generator with multiplex mask filters
- 25 specially tuned Factory presets
- Front panel setup and configuration menu eliminates the need for a PC during installation



# AM-10HD

AM HD Audio Processor

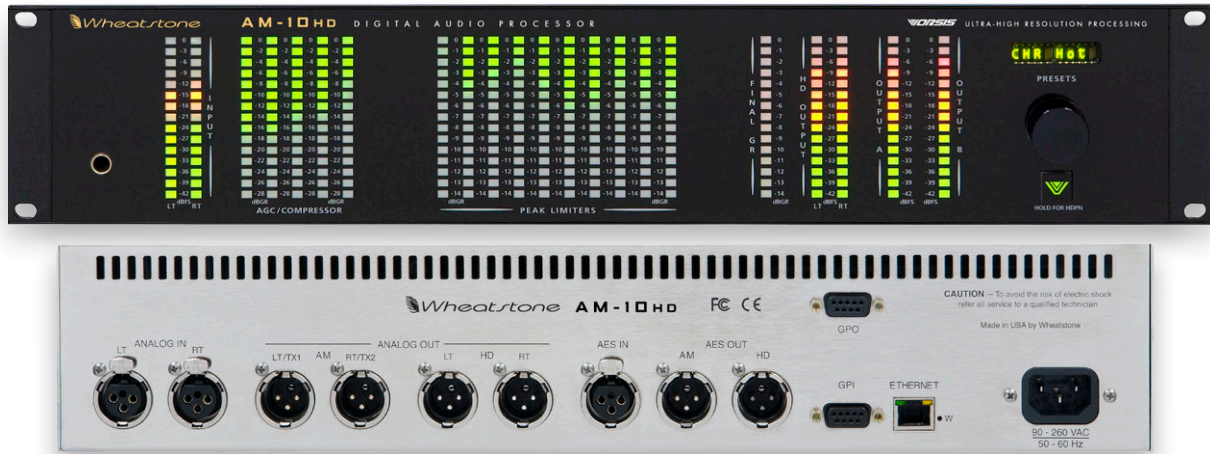

Who says AM isn't competitive? The AM-10HD for AM or AM+HD broadcast has a five-band AGC followed by a specialized 10-band limiter and high-performance asymmetrical modulation peak controller algorithm that has been specially designed for the requirements of competitive AM broadcasting.

The AM-10HD puts your AM station up front and center on the dial with several key Vorsis technologies. It has a peak controller that maximizes AM coverage by providing the highest possible average modulation accompanied by consistent positive peak capability of up to 200%. Selectable low-pass filters are available to tailor the output for the requirements of various regulatory needs. The HD signal path includes its own specialized multiband peak controller which has been tailored for the codec that is utilized in AM HD broadcasting.

Another significant competitive tool in the AM-10HD is the Vorsis Bass Management System (VBMS), which essentially circumvents bass-related distortion plaguing other broadcast audio processors. It works by monitoring program energy in different parts of the audio spectrum while manipulating the behavior of the final peak limiter. The result is increased bass impact and detail without affecting the clarity of mid and high frequency program — in fact bass detail and the clarity of higher frequency audio are enhanced by the VBMS algorithm.

Then there's our Smart Stereo Enhancement. Stereo enhancement is a common feature in audio processors today. However, our Smart Stereo Enhancement operates in the sum and difference domain and under the management of specialized automatic level and spectral management algorithms. The result is an extremely stable 'on-air' stereo image that is wide, alive, exciting to listen to, and yet still natural sounding. End users have reported hearing artistically important nuances in music that were simply inaudible after being processed by competing products.

Also of significance is our Spectral Limiter with Adaptive Filter Bank. The AM-10HD's ten-band final limiter reconfigures its crossover frequencies as the AM output low pass filter bandwidth setting is changed, resulting in a very powerful AM audio processor that always has ten bands of final limiting regardless of how narrow the output low pass filter is adjusted. This results in maximum loudness and perceived quality on typical consumer AM receivers. Likewise, the five band AGC's crossovers have been optimized so that all five bands of AGC are available, even down to a 4.5kHz output bandwidth.



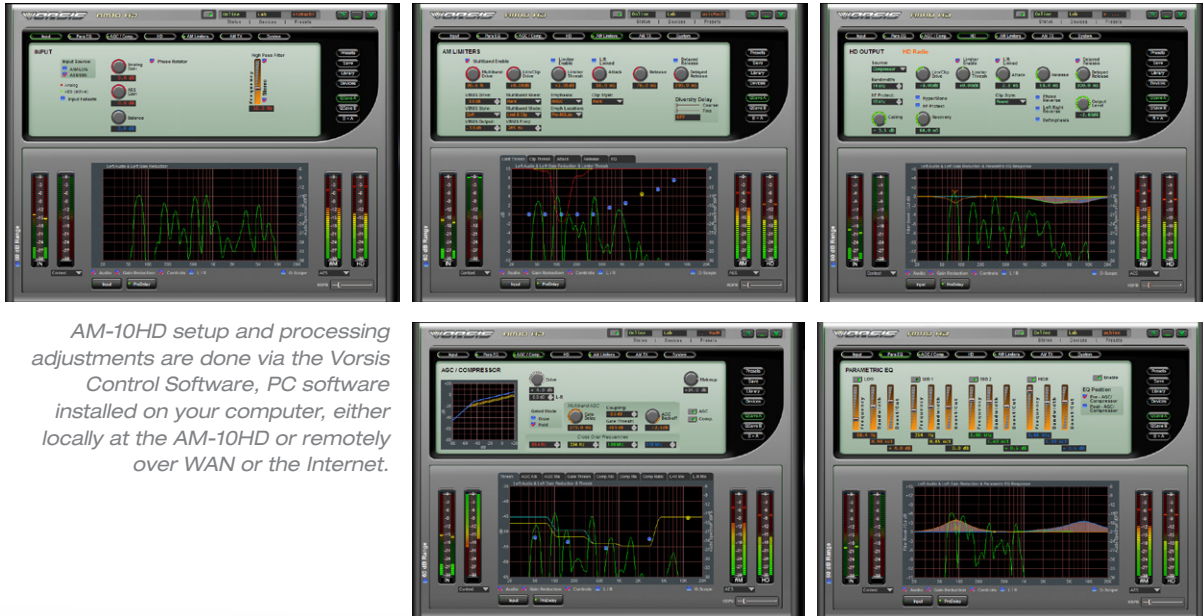

AM-10HD setup and processing adjustments are done via the VORSIS Control Software, PC software installed on your computer, either locally at the AM-10HD or remotely over WAN or the Internet.

- Dozens of pre-installed factory presets with lots more downloadable from the Wheatstone-processing website to get you sounding great fast
- Selectable all-pass filter for making voice's energy more symmetrical
- Adjustable input high pass filter may operate in stereo or M/S modes
- Onboard storage for up to 80 user presets
- 5-band dynamics controller
- 10-band limiter/clipper with integrated bass management
- Three 4-band parametric equalizers - each may be placed before/after multiband section
- Separate peak control signal paths for AM analog and AM-HD digital broadcast
- Special codec pre-conditioning processing to reduce HD-induced distortion
- Automatic audio source failover on analog and digital audio inputs
- Separate audio input gains for analog and digital inputs
- Five band linear phase crossover with adjustable crossover points
- Advanced Distortion Masked clipper for absolute peak control
- Adjustable positive asymmetry
- LF tilt correction and dual transmitter outputs - 4.5kHz, 5kHz, 6kHz CCIR and 10kHz NRSC lowpass filters supported
- Separate HD signal chain processing, final limiter, and digital output
- Diversity delay for HD, adjustable to 10 seconds
- Headphone monitoring of critical stages of the processing
- Remote controllable using the VORSIS Control Software over TCP/IP via LAN/WAN or the Internet
- Preset switching via opto-isolated GPI

# M4-IP BLADE

Four Channel Mic Processing BLADE



Four announcers, one rack unit and four mic processors that are accessible from anywhere in your WheatNet-IP network, the M4-IP is a four-channel DSP-based voice processor with four completely independent channels of high quality voice processing.

The M4-IP Microphone Processor BLADE combines four high-quality microphone preamps, four channels of Vorsis Embedded microphone processing, and a WheatNet-IP BLADE interface, allowing you to place four microphone inputs anywhere in your WheatNet-IP Intelligent Network (although it also works just fine as a standalone processor). The preamps and processors are accessed and controlled from any point on the network via its Windows-based GUI.

The M4-IP is a great way to maximize your investment in on-air talent by combining four mic processors into a single rack space, accessible from anywhere.

The M4-IP microphone processor is equipped with four matched Super-Quiet (SQ) microphone preamplifiers featuring extremely low noise floor, very wide dynamic range, faithfully accurate transient response, and ruler flat frequency response. Operating in harmony with high quality 24-bit A/D converters and a 96kHz base sample rate, the M4-IP adds absolutely no undesired coloration to the signal and faithfully preserves the sound of any microphone and talent combination. It also features a four-section equalizer with high and low shelving EQ and two bands of fully parametric EQ, high and low pass filters, and de-esser and expander functions.

The signal path of the M4-IP includes four completely independent channels of Wheatstone's smooth-sounding Vorsis dynamics processing. Adjustable from anywhere on your network the M4-IP offers the security of password protected TCP/IP-based remote control and no front panel controls. Included in the M4-IP dual-channel voice processor is Wheatstone's smooth-sounding Vorsis dynamics processing.

### Wheatstone-designed Equalization

Based on great-sounding designs built for Wheatstone's high performance professional audio applications, the M4-IP's equalization section operates predictably and adds no noise, ringing, phasiness or other undesirable coloration to the sound.

### Wheatstone-designed Dynamics Processing tools

A high performance and fully adjustable downward expander, de-esser, and smooth sounding broadband compressor and selectable low distortion final Lookahead limiter round out the M4-IP to create powerful and authoritative presence to production or on-air microphones.

### Processing Presets

A variety of ready-to-use factory processing presets are provided, carefully tailored for different processing goals and formats. You can select a factory preset, confident that it will sound great just as it is. Or use a factory preset as a starting point and create a custom sound for each announcer, then save the new settings as a personalized user preset. In a facility with multiple microphone processors, presets saved in one unit can be easily copied to the others.

### Wheatstone Talent Control Interface

The Wheatstone Talent Control Interface software can reside on an air studio/control room PC and gives talent the ability to recall presets from any VORSIS microphone processor without allowing processing adjustments.

All parameters of the M4-IP are controlled using the included Windows-based GUI. Voice talent can activate his or her own personal sound at the press of a button using the Talent Control Interface, a special GUI designed for preset recall only.

- Extremely high performance microphone preamplifiers with 48V phantom power
- Four completely independent processing channels
- All digital, field proven Wheatstone-designed advanced processing algorithm
- Phase Scrambler to correct asymmetrical voice waveforms
- High- and low-pass filters as well as an adjustable High-Q notch filter
- Fully adjustable downward expander
- Precision de-esser sibilance controller
- Four-bands of EQ: low-frequency shelving, two-band parametric, high-frequency shelving
- Compressor: broadband, two, or three bands
- Final precision peak limiter – can be defeated if desired
- TCP/IP-based remote control from anywhere via VORSIS Remote Control Software
- Talent Control Interface software for preset recall without processor control
- Password controlled access and control-less front panel for keeping settings secure
- Full metering of input and output levels and all signal processing
- FFT and oscilloscope displays of pre and post processing audio
- Requires only one rack space

# M1 & M2

## Voice/Mic Processors



The M1 is a flexible digital microphone processor. It offers unlimited presets, security and networkability in an all-digital framework, with easy-to-set up parameters. Either from the front panel, or from the GUI - all parameters of the M1 can be controlled to give each voice talent his or her own personal sound at the press of a button. The M2 is a dual-channel DSP-based voice processor. The M2 is able to operate in completely independent dual channel mode or, at the touch of a button, M/S mode for professional stereo recording applications.

Your on-air voices need to be clean, clear and distinct. On-air processing tuned for music just doesn't produce an optimum voice sound - you want your jocks to have punch that cuts through the music. You want a versatile production tool that can sweeten voiceover sound. You want to deliver consistent sound from talent to talent regardless of widely varying voice characteristics. One intelligent voice processor with individualized presets can handle it all - that perfectly describes Wheatstone digital voice processing.

Both the M-1 and M-2 begin with high-quality microphone preamplifiers approaching theoretical perfection - clean, transparent, and extremely low noise. Each preamp feeds wide dynamic range 24-bit analog-to-digital converters operating at 96kHz for absolute sonic accuracy. From then on, all processing is done in the digital domain by Vorsis algorithms optimized for broadcast voice. EQ, filtering, dynamics, downward expander noise gate and de-essing—everything you need to create your ideal voice sound.

Like all Wheatstone processors the M-1 and M-2's operating parameters are adjustable via Vorsi Remote Control Software installed on your PC. Up to 255 processors in a facility can be operated from a single control screen.

**M-1** Ideal as a production studio tool—a single-channel voice processor with all processing controls available right on the front panel.

**M-2** A dual-channel voice processor best suited for on-air talent processing. Set once and forget, or create individualized talent settings using custom presets - all recallable via software or automation control. No front panel controls to tempt well meaning but sometimes curious staff.

The M-2 includes an enhanced compressor section capable of operating in up to three bands. Producing a more consistent sound with fewer artifacts than a wideband compressor, it provides the benefits of dynamic spectral enhancement, maintaining bass and brightness balance over changing input levels and talent voice characteristics.

### Processing Presets

A variety of ready-to-use factory presets are provided, all carefully tailored for different processing goals and formats. You can select a factory preset, confident that it will sound great just as it is. Or use a factory preset as a starting point and create a custom sound for your station - or even for each announcer. Then save the new settings as personalized user presets. In a facility with multiple microphone processors, presets saved in one unit can easily be copied to the others.



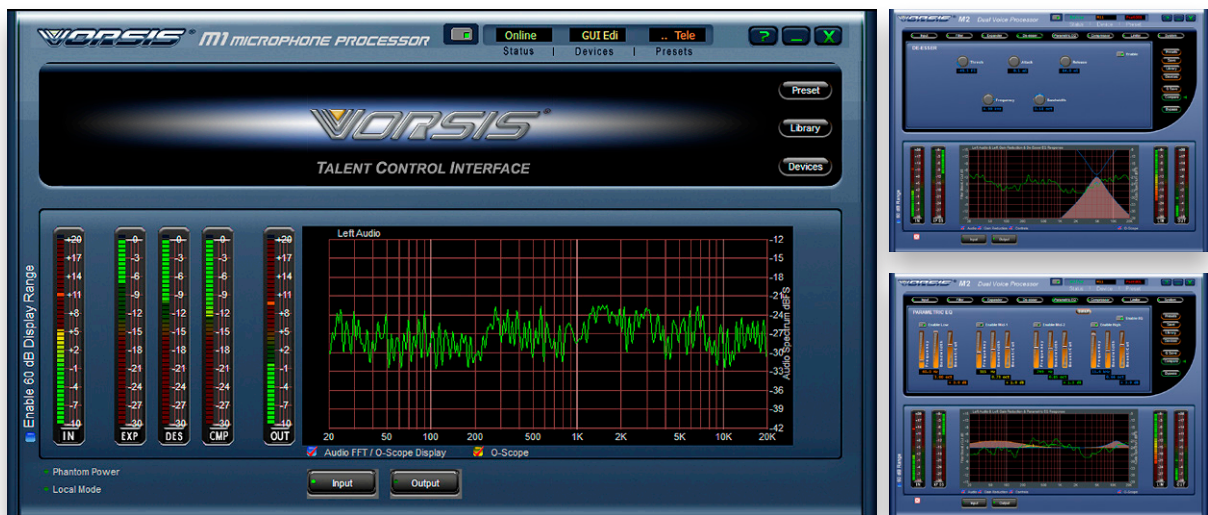

### Vorsis Talent Control Interface

The Vorsis Talent Control Interface software can easily reside on an air studio/control room PC and gives talent the ability to recall presets from any Vorsis microphone processor—but does not allow any adjustments to audio parameters. The interface presents a large high-resolution FFT and scope display of talent real-time voice audio, as well as input and output levels.

There's also a mini Talent Interface window that takes up only a small amount of screen real estate for simple recall of saved presets without visual metering.

### Vorsis Control Software

In the M-1, processing adjustments are made at the front panel or via Wheatstone's Vorsis Control Software. In the M-2, all controls are accessed via the software; the front panel has no controls, only metering.

The Vorsis Control Software – separate versions for the M-1 and M-2 – loads on an external PC. You can connect the PC directly to the processor, or install the processor on your station's Ethernet LAN and access it from anywhere in your network (or remotely over VPN).

With Vorsis Control Software no adjustment is more than two mouse clicks away. And unlike other processors, every processing control is available and labeled for exactly what it does, giving you ultimate power to create your ideal sound.

The remote control screen is divided into an upper control area and a lower dynamic section that includes real-time display of gain reduction as well as a frequency-domain graph that shows the spectral characteristics of your audio. Every screen also includes accurate metering of input and output peak and average levels. Tabs across the top of the GUI software allow immediate access to each section of the processing.

Features for M-1 and M-2 unless otherwise noted

- M-1: one processing channel
- M-2: two processing channels
- M-1: front panel controls and control via Vorsis Remote Control Software
- M-2: all control is via Vorsis Remote Control Software
- All digital, field proven Vorsis-designed advanced processing algorithms
- Vorsis Remote Control Software to adjust the settings from your PC, locally or remotely
- Talent Control Interface software for preset recall without processor control
- High performance microphone preamplifiers with phantom power
- High- and low-pass filters; the M-2 also includes an adjustable High-Q notch filter
- Downward expander
- Phase Scrambler to correct asymmetrical voice waveforms
- De-esser precision sibilance controller
- Four-band EQ: low-frequency shelving, two-band parametric, high-frequency shelving
- Compressor:
  - M-1: single band
  - M-2: up to three bands
- Final precision peak limiter (M-2 only)



 **Wheatstone**

SAVE DIFFUSION 23 rue de la Talaudière  
42000 ST-ETIENNE FRANCE tel. 04 77 79 46 78  
commercial@savdiffusion.fr - www.savdiffusion.fr

Wheatstone Corporation  
600 Industrial Drive • New Bern NC 28562-5440 USA  
phone 1.252.638-7000 • fax 1.252.635-4857  
wheatstone.com • sales@wheatstone.com